

Volume 12 / Number 2 / July 1994

## Testing the RP

### An Optional Direction-of-Flow Test for the No. 2 Check Valve

In testing the reduced pressure principle backflow prevention assembly the tester obtains numerical values for the first check and for the relief valve. In some

This test can only be completed accurately if no downstream shutoff valve leak is present. To determine if the second shutoff valve is leaking the tester must close the No. 2 test cock when the gage is attached as in

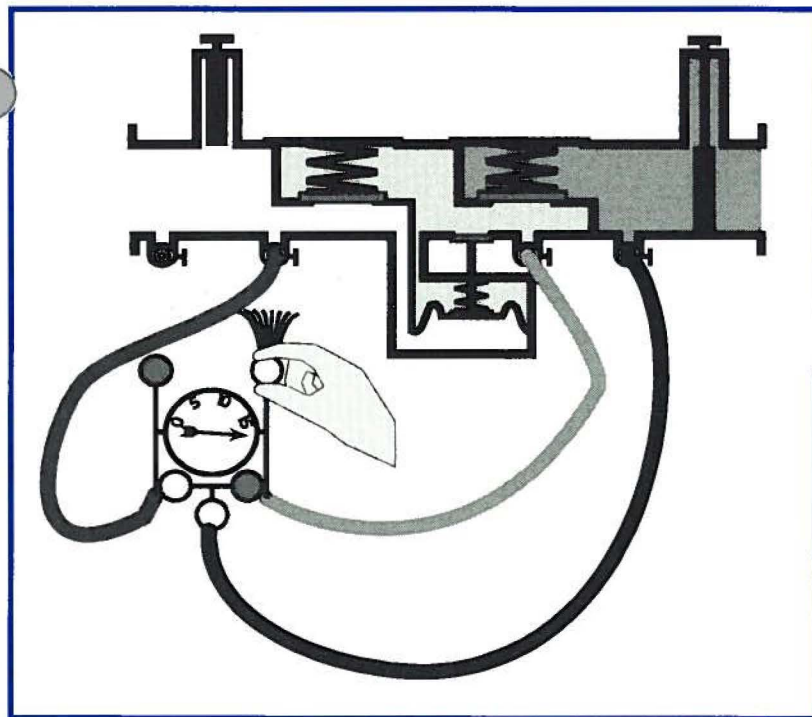

Figure 1

cases certain administrative authorities may ask for a numerical value on the second check based on a direction-of-flow test. The Appendix of the ninth edition of the *Manual of Cross-Connection Control* contains test procedures for obtaining a numerical value for the second check as an optional field test procedure.

leaking. From this point the tester follows the instructions as listed here.

- Close test cocks No. 3 and No. 4. Remove test equipment.
- Attach hose from the high side of the differential pressure gage to the No. 3 test cock.

continued on page 3

## Failing Assemblies

### When an Assembly Fails the Field Test, Does Backflow Occur?

What does a tester mean when he or she states that a backflow preventer failed? Does this mean the assembly failed to prevent backflow and a domestic water supply was contaminated? Does this mean the assembly won't prevent backflow if a backflow condition exists? Or, does this mean the assembly didn't pass the field test but will still prevent backflow?

Any of the above situations may be true, but not necessarily all three. For example, if a tester tests a double check valve assembly in the direction

continued on page 4

## Highlights

• 'Failed' Assemblies

• Foundation Highlights - 1967

• Direction of Flow Test for Second Check of RP



# Membership

The Foundation Membership grew again in this last quarter. The newest Members are listed below. The Foundation encourages Members to take advantage of the many benefits of Foundation Membership. Additional copies of the *Manual of Cross-Connection Control* are available to Members at a 25% discount. Members receive a 20% discount on training courses and 25% discounts on the Training Tools. Members are also encouraged to contact the Foundation office with any questions regarding cross-connection control.

A.R. Amable Plumb. & Htg. Co.  
 ABC Trailer Park  
 Absolute Backflow Control  
 Advance Testing & Service  
 Advantage Backflow Testing  
 Ambitec  
 Anheuser-Busch, Inc.  
 Arizona Certified Backflow Testers  
 Arizona Pub. Serv. Co.,  
     Palo Verde N.G.S  
 Arnold Linné  
 Backflow Certification Inc.  
 Backflow Eliminator  
 Bermuda Water Company, Inc.  
 Big Park Water Company  
 Bob's Plumbing Inc.  
 City of Bozeman  
 Bryan Brigham  
 Bud Veach  
 Central Valley Chapter - A.B.P.A.  
 City of Chappell  
 Childrens Hospital - Los Angeles

D & R Plumbing  
 D & T Trainers  
 Disneyland  
 Ed Grace Co., Div. of  
     Shambaugh & Son  
 Erie Waterworks  
 City of Eureka Springs  
 Florida Rural Water Assoc.  
 Food 4 Less  
 Fushman Co., Ltd.  
 City of Gallup, Joint Util. Div.  
 Haendiges Plumbing Co., Inc.

City of Holtville  
 The Island Water Association, Inc  
 Intel Corporation  
 J.L. Walker Vocational - Tech. Center  
 Johnson Controls World Services  
 Joint Apprenticeship & Train. Comm.  
 Karsten Manufacturing Corporation  
 Kingsbury General Improvement Dist.  
 City of Las Vegas  
 Lawson's Landscape Services  
 LeDuc & Dexter Inc.  
 Long Beach Dept. of Health  
     and Human Services  
 Mr. Ken Maejima  
 M & J Backflow Service  
 Miami Dade Water and Sewer Dept.  
 City of Mountain View  
 Multi Water Systems  
 Nelson Carlson Mechanical  
     Contractors  
 City of North Las Vegas  
 City of Palo Alto  
 P.T. Morimura & Associates  
 Pennex Backflow Prevention  
 Port of Oakland  
 Ray Zierman Plumbing, Inc.  
 Mr. Jeff Richardson  
 RJP Construction Inc.  
 San Bernardino Valley College  
 South Coast Plaza  
 City of South Sioux City  
 Town of Snowflake  
 SPC Marketing  
 Stewart Plumbing  
 Sutton Plumbing Service

Trentco  
 Underwriters Laboratories Inc.  
 University of Kansas  
 Utility Supply Company  
 Valparaiso Dept. of Water Works  
 Vaughn Irrigation Services, Inc.  
 City of Vernon  
 Virginia Department of Health  
 W.C. Service Company, Inc.  
 Warren Williams  
 City of Wasco Water Dept.  
 Water Metrics West  
 Willis Plumbing



*Cross Talk* is published by the University of Southern California's Foundation for Cross-Connection Control and Hydraulic Research for its Members. Additional Copies are available to the Members upon request. (213) 740-2032 Copyright 1994 © University of Southern California. All rights reserved.

# Testing the RP

*continued from page 1*

- Attach hose from the low side of the differential pressure gage to the No. 4 test cock.

- Open test cocks No. 3 and No. 4, and bleed all air from the hoses and gage by opening the high side bleed needle valve and the low side bleed needle valve.

- Close the high side bleed needle valve, then slowly close the low side bleed needle valve.

- After the gage reading stabilizes, the steady state differential pressure reading indicated on the gage is the static pressure drop across check valve No. 2 and is to be recorded as such. This reading must be 1.0 psi or greater.

- Close all test cocks, slowly open shutoff valve No. 2, and remove all test equipment.

This brief optional test allows the tester to determine the static pressure drop across the No. 2 check valve of the reduced pressure principle backflow prevention assembly. By design, the No. 2 check valve of the reduced pressure principle backflow prevention assembly must hold a static differential of at least 1.0 psid.

In many cases testers who do not use the direction-of-flow test, as noted above, on the reduced pressure principle backflow prevention assembly still record a numerical value for the No. 2 check valve. This comes from a misunderstanding of the test. One of the first items noted during the test is the *apparent reading* across the No. 1 check valve. This reading is only noted and should

never be recorded. This is simply used to compare against the *actual reading* across the No. 1 check valve

---

## ***This brief optional test allows the tester to determine the static pressure drop across the No. 2 check valve of the reduced pressure principle backflow prevention assembly***

---

which is recorded in Test No. 3. These readings may vary slightly due to a small downstream shutoff valve leak. Test No. 3 compensates for this slight leak, thus giving the actual No. 1 check valve reading. If the optional direction-of-flow test is not used on

the No. 2 check valve, the check valve may only be recorded as either leaking or closed tight. However, some testers have mistakenly recorded the *apparent* reading as the *actual* reading across the No. 1 check valve and the *actual* reading as the No. 2 check valve reading.

If the tester used the direction-of-flow test on the No. 2 check valve of the reduced pressure principle backflow prevention assembly, then a numerical value should be recorded. This number will, however, not be similar to the No. 1 check valve. The No. 2 check valve reading must be at least 1.0 psid in the direction of flow. In most cases the reading will be between 1.0 and 3.0 psid.

*continued on page 7*

### ***Tester Course***

#### **The Foundation Laboratory**

11 - 15 July 1994  
3 - 7 October 1994  
23-27 January 1995

#### **Incline Village, NV**

1 - 5 August 1994

#### **Redding, CA**

22-26 August 1994

**Non-Members \$750.00**

**Members \$600.00**

### ***Program Specialist Course***

#### **USC Campus**

18 - 22 July 1994  
30 January -  
3 February 1995

#### **Monterey, CA**

12 - 16 September 1994

**Non-Members \$800.00**

**Members \$640.00**

Courses may be added throughout the year. Please contact the Foundation office for information on courses in your area or for an application for the next USC Training Course. You may also send a hard copy of a purchase order or a check to the Foundation office to reserve a space. Please be advised that some of these courses fill six to eight weeks in advance.

A Purchase Order may be sent via FAX to the Foundation office at (213) 740-8399 or call (213) 740-2032 for more information.



## Failing the Field Test

*continued from page 1*

of flow and finds the first check to be holding a differential of 1.2 psid and the second check to be holding a differential of 0.8 psid, the tester may state "the assembly fails." In this case, the tester means the assembly fails to meet the test criteria for a field test as stated in Section 9.3.2 of the *Manual of Cross-Connection Control*. In fact, the No. 1 check valve is within the design criteria but the No. 2 check valve is not operating at its full design potential, as required. Therefore, the assembly fails the field test. The No. 2 check valve

***Since the assembly is not operating at its full design potential, as required, the assembly fails the field test***

is holding in the direction of flow. However, the No. 2 check valve is not holding the required 1.0 psid. Should a backflow condition exist, would backflow occur through this double check valve assembly? No. Since the check valves are still holding, backflow would not occur. However, since the assembly is not operating at its full design potential, as required, the assembly fails the field test. The tester is now aware of the condition and should repair the assembly to get it back to its full design potential.

In another example, the tester may be testing a reduced pressure principle backflow prevention assembly. In the remote case that the relief valve fails to open and both check valves leak, the potential for backflow to occur through the assembly now exists. This means that the assembly fails the field test, but also it means that the assembly is failing to prevent backflow. This type of failure presents a more

immediate danger to the potable water supply. Hydraulics could change in the system at any time causing backflow to occur

***Although the assembly does not meet the design requirements, the assembly will still prevent backflow***

through the assembly. When the tester states "the assembly fails," in this case, the tester means the assembly fails to prevent backflow, as well as fails to pass the field test requirements.

A tester may test a reduced pressure principle backflow preven-

tion assembly and find the differential pressure relief valve opening point to be 2.4 psid and the actual reading across the No. 1 check valve to be 5.0 psid. When this occurs there is a buffer between the readings of 2.6 psid. The buffer should, however, be 3.0 psid. Although the assembly does not meet the design requirements, the assembly will still prevent backflow. Some administrative authorities do not require backflow preventers under their jurisdiction to meet this 3.0 psid buffer requirement. In this case, the field test would be acceptable. However, it should be noted that an administrative authority should have a minimum buffer requirement. If there is no buffer requirement, then it would not

*continued on page 5*

## Manual Available

**The Ninth Edition of the Manual of Cross-Connection Control is available for purchase. Foundation Members receive a 25% discount from the list price of the Manual. Manual Pricing is as follows:**

<b>Members</b>	<b>\$36.00</b>
<b>Non-Members</b>	<b>\$48.00</b>

**Manuals are typically shipped each Friday. To order Manuals a purchase order or check may be sent to the Foundation office. To expedite the order a purchase order may be sent via FAX. If next day or second day shipping is required, there is an extra fee.**

**Foundation for Cross-Connection Control  
and Hydraulic Research  
University of Southern California  
KAP-200 University Park MC-2531  
Los Angeles, CA 90089-2531  
(213) 740-2032  
FAX (213) 740-8399**



## Failing the Field Test

*Continued from page 4*

It is possible to determine if the No. 1 check valve is operating properly. The No. 1 check valve could hold a pressure differential of 1.0 psid while the relief valve opens at 3.0 psid. When this occurs it is not possible to determine if the No. 1 check is holding at all because the relief valve will discharge whenever there is a no-flow condition. Backflow will still be prevented if, in fact, the No. 1 check is holding. If, however, the No. 1 check valve is leaking, the assembly would react in the same manner. This is why the first check valve must have a requirement of holding at a specific value above the

relief valve opening point. The Foundation encourages the 3 psid requirement as this is the design requirement from Section 10.2.2.3.5 of the *Manual of Cross-Connection Control*. Any value less than this is

***The failure of a field test does not directly correlate to the occurrence of backflow***

an indication that the assembly is not performing to its full design potential and it may need repair.

Failure rate statistics are commonly used when discussing the

use of backflow prevention assemblies. The failure rates are somewhat taken out of context since it is assumed that a "failure" means backflow can occur through the assembly. However, the failure of an assembly to meet the field test criteria does not imply this at all. For backflow to occur through an assembly, the check valves must be physically fouled or damaged (0.0 psid). Therefore, a critical review of failure rate data must be made to determine what constitutes a "failure." The failure of a field test does not directly correlate to the occurrence of backflow. ♦

### Cross-Connection Control Informational Brochures

The informational brochure entitled *Working Together for Safe Water* is a great complement to *Essentials of Cross-Connection Control* or the film *Working Together for Safe* all the concepts of cross-connection control to your audience using you can hand out the brochure. This gives those in attendance something to take with them which will help them to comprehend fully the topics discussed.

The brochures come with the name, address and telephone number of the ordering agency, so those who desire more information or have questions, can call you directly.

This brochure can be used to explain the basic concepts of cross-connection control, helping water users understand why they may need to install a backflow preventer or comply with

***Your Name, Address  
and Phone Number  
Printed on the Back***

periodic testing requirements. To request a sample of the brochure with an order form, contact the Foundation office at:

Foundation for Cross-Connection Control  
and Hydraulic Research  
University of Southern California  
KAP-200 University Park MC-2531  
Los Angeles, CA 90089-2531  
(213) 740-2032  
FAX (213) 740-8399

the slide presentation *The Water*. You'll be able to explain the slide presentation. Then,

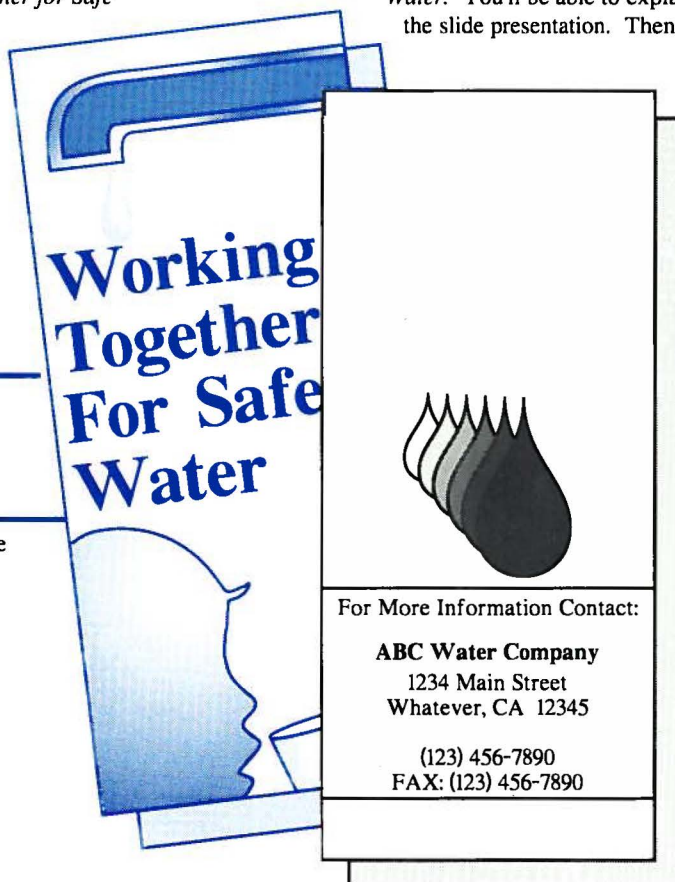

For More Information Contact:

**ABC Water Company**  
1234 Main Street  
Whatever, CA 12345

(123) 456-7890  
FAX: (123) 456-7890



# Historical Highlights - 1967

## *The Membership Program Established*

This year the Foundation is celebrating its fiftieth anniversary. An open house is being tentatively planned for September 30th at the Foundation Laboratory. All Members of the Foundation will receive an invitation with the details once the plans are finalized.

The Foundation has had many exciting events occur throughout its half century history. The Membership Program, for example, was founded in 1967. Originally the Southern California Water Utilities Association (SCWUA) organized the Foundation's Membership program by asking its Members to donate funds for the Foundation's work. Most of the Foundation's original support was inspired by Mr. Walter Weight. Mr. Weight worked tirelessly visiting various water agencies in the region, encouraging them to participate in the Foundation's Membership Program. For years the SCWUA actually managed the Foundation's Membership fees. The SCWUA collected the Foundation's Membership fees from its Members which chose to participate in the Foundation's Membership Program, transferring funds to the Foundation when they were collected.

In the photo from 1967 the original check for \$10,000 establishing the Foundation Membership Program is handed to Dr. Norman Topping, President of the University of Southern California from Walter Weight, Chariman of the SCWUA. Next to Walter Weight is Professor E. Kent Springer (left), Director of the Foundation (now Director Emeritus) and A. C. Ingersoll (right), Dean of the School of Engineering is standing next to President Topping. ♦



The Charter Members of the Foundation were:

- Azusa Valley Water Company
- Baldwin Park County Water District
- City of Burbank
- California Cities Water Cop.
- California Domestic Water Service
- Central Basin Municipal Water District
- City of Compton
- City of Covina
- Diamond Bar Water Company
- City of Downey
- City of El Monte
- City of El Segundo
- City of Inglewood
- Irvine Ranch Water District
- La Habra Heights Mutual Water Company
- Las Virgenes Municipal Water District
- City of Long Beach
- City of Los Angeles
- City of Lynwood
- Malibu Water Company
- City of Manhattan Beach
- City of Monrovia
- City of Monterey Park

- Newhall County Water District
- City of Ontario
- City of Oxnard
- Palos Verdes Water Company
- Palmdale Irrigation District
- Park Water Company
- City of Pasadena
- City of Pomona
- City of Redlands
- Rowland Area County Water District
- City of San Bernardino
- City of San Diego
- San Diego County Water Authority
- San Gabriel County Water District
- San Gabriel Valley Water Comapny
- City of Signal Hill
- City of South Pasadena
- City of Torrance
- Upper San Gabriel Valley Municipal Water District
- Vallecito Water Company
- City of Ventura
- City of Vernon
- Walnut Valley Water District
- West Basin Municipal Water District
- City of Whittier
- Yorba Linda County Water District
- Yucca Valley County Water District



## Testing the RP

*continued from page 3*

Should the No. 2 check valve hold a differential less than 1 psid, the check valve is still holding and it is preventing backflow. However, the check valve is not operating at its full design potential as it is designed to operate. The Foundation's perspective on this is the check valve fails. It is important to understand that the check valve fails the field test criteria, thus failing the field test of the assembly even though it is not possible for backflow to occur through the assembly.

A similar situation occurs with the 3.0 psi buffer between the actual reading of the No. 1 check valve and the opening point of the relief valve. The No. 1 check valve should have a reading of at least 3.0 psi greater than

the relief valve opening point. This is a design criteria to limit the amount of relief valve discharge due to line pressure fluctuation. If the buffer is less than 3.0 psi, the assembly will still prevent backflow. However, the assembly is not operating at its full design potential; this indicates there is a problem of sorts. The Foundation's perspective, in this situation, is the assembly fails. The actual reading of the No. 1 check valve must be at least 3.0 psi above the relief valve opening point in order for the assembly to pass.

Some administrative authorities do not make the 3.0 psi buffer a requirement. In these jurisdictions, it is important for the tester to know what is considered acceptable. Some value must be set as the limit. If no

buffer is required the actual reading of the No. 1 check valve could be less than the relief valve opening point. If this were the case, there would be no way of determining if, in fact, the No. 1 check valve was holding at all since the reading is no longer accurate once water is passing through the No. 1 check valve to the relief valve. ♦

## Walter Weight

As mentioned in the last issue of *Cross-Talk*, the Ninth Edition of the Manual of Cross-Connection Control was dedicated to Mr. Walter Weight and the late Mr. William Whiteside. Since the last issue of *Cross Talk*, we are sad to report, Mr. Walter Weight passed away. Walter Weight was ninety-eight years old. He was instrumental in the growth of the Foundation, particularly in the area of the Foundation's Membership Program. It was through him that the Membership Program of the Foundation was initiated. As shown on the opposite page Mr. Weight raised support for the Foundation from Members of the Southern California Water Utilities Association (SCWUA), thus beginning the Foundation's Membership Program.

Mr. Weight was also extremely active in the water works industry contributing greatly to the safe distribution of water nationwide. Many friends and relatives have made contributions to a scholarship fund at the Foundation in honoring these cross-connection control pioneers. If you are interested in making a scholarship fund contribution, you can do so through the Foundation office. ♦

### **Research Contract for Effective Metering Awarded to the Foundation**

The Foundation has recently received a research contract from the Southern California Water Company to develop a computer program for effective metering of large water meters. The program will analyze the consumptive use pattern of the meter account and incorporate an economic analysis to determine the optimum strategy for the maintenance of water meters.

In the photo: Larry Metzger, graduate student working on the project, Dr. J. J. Lee, Director of the Foundation; John Nelson and John Spitler, representatives of the Southern California Water Company.

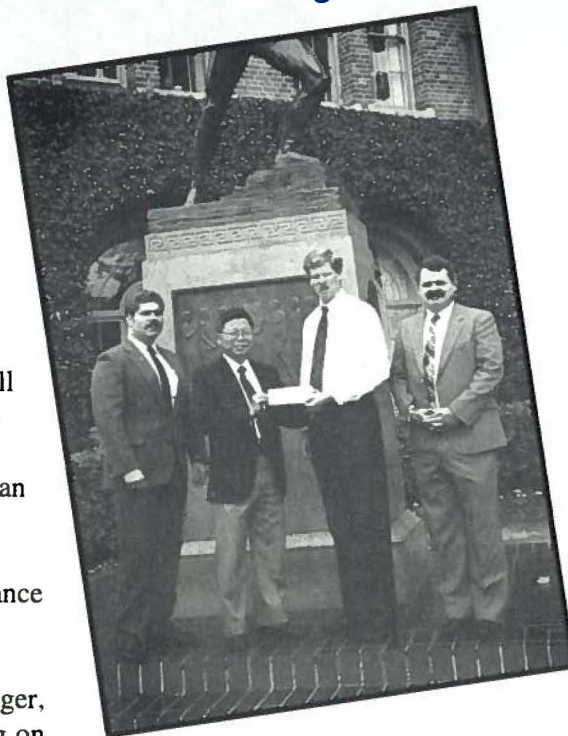

# Calendar of Events

*This calendar shows some of the activities which the Foundation is currently planning on participating in. For more information contact the Foundation office.*

**11-15 July 1994** - Tester Course, Foundation Laboratory, Los Angeles, CA

**18-22 July 1994** - Program Specialist Course, USC Campus, Los Angeles, CA

**1-5 August 1994** - Tester Course, Incline Village, NV

**17 August 1994** - Joint Instrumentation Conference, Santa Ana, CA

**22-26 August 1994** - Tester Course, Redding, CA

**31 August 1994** - Northern California Backflow Prevention Association, CA

**11-13 September 1994** - American Water Works Association Distribution Systems Symposium, Omaha, NE

**12-16 September 1994** - Program Specialist Course, Monterey, CA

**21 September 1994** - Inland Counties Cross-Connection Control Group

**26 September 1994** - California-Nevada Section American Water Works Association Seminar, Sacramento, CA

**30 September 1994** - Foundation Open House, Foundation Laboratory, Los Angeles, CA (Tentative)



FOUNDATION FOR CROSS-CONNECTION CONTROL  
AND HYDRAULIC RESEARCH  
UNIVERSITY OF SOUTHERN CALIFORNIA  
KAP-200 University Park MC-2531  
Los Angeles, California 90089-2531

First Class Mail  
U. S. Postage Paid  
University of  
Southern California