

inside: **list deletions** | **field testing the rp** | **abpa cert at specialist course**

Cross Talk

Autumn 2008

Winterizing Backflow Prevention Assemblies

As the winter months draw near its important everyone be aware of the effects the cold temperatures may have on water pipes and backflow prevention assemblies. Many

cause them to burst and may cause permanent damage in shutoff valves that are a part of backflow prevention assemblies. Winterizing involves the water being drained out



will be winterizing portions of their water systems, which include backflow preventers (including shutoff valves). Others will use enclosures to protect backflow preventers from freezing.

When water freezes it occupies a greater volume than in its liquid form. The ice causes pressure to build inside the pipes that can

of the water line prior to the winter months. Freezing water has damaged or destroyed both backflow preventers and shutoff valves.

Even with the winterizing of a water line the ball valves may be left in the fully opened or fully closed position. When this is done there may be a small volume of water trapped between the outside of the ball and the body.

continued on **page 4**

Contents

List **Deletions** p. 3

Field **Testing** the **RP**- Leaky #2 SOV p. 5

ABPA certification at **Specialist Courses** p. 6

Reminder: Member **Rates** p. 7

Foundation Membership

The Foundation's Membership Program provides many benefits to the Members of the Foundation. These include: a twenty-five percent discount on manuals, twenty percent discount on Foundation Training Courses for ALL EMPLOYEES of the Member company/organization, the *List of Approved Backflow Prevention Assemblies* with access to the up-to-the-minute version on the Foundation's website.

Members are encouraged to call the Foundation with technical questions. The Foundation's Engineering Staff is available to assist Members with the various aspects of field testing backflow preventers, installing backflow preventers and administering their cross-connection control program.

Below is a list of those who have become members of the Foundation this past quarter:

A.W. & Sons Plumbing	Garcia Plumbing, Inc.
Anderson Systems	Inland Empire Utilities Agency
Arroyo Plumbing, Inc.	James City County
Bexar Metropolitan Water District	KOCCC
Cal Poly State University	Louisville, City of (Colorado)
California Rural Water Association	Mariposa Public Utility District
Carlsbad Municipal Water District	Oakenshaw, Inc.
Chem Pro Laboratory, Inc.	Operations Management, Inc.
DEMA Engineering Co.	Phoenix, City of
Dubuque, City of	Poker Bar Services, Inc.
Edwin Fajardo	PPATKS
EMD, Inc.	Rick Engineering Company
Essential Fire Protection	Rio Tinto Minerals
Evergreen Valley Utilities	Ryder Houston
Fernley, City of	United Drain & Plumbing
FESS	Waffle House, Inc.

**Cross Talk is published by the Foundation
for Cross-Connection Control and Hydraulic Research at the
University of Southern California for Foundation Members.
Limited additional copies are available to Members upon request.
2008 © University of Southern California.
All rights reserved.**



List Deletions

The List of Approved Backflow Prevention Assemblies continues to be an essential tool for many in the cross-connection control industry. And, occasionally the List notes assemblies that have been deleted or modified. Recently, the Foundation made several deletions from the List that caused a number of members to enquire about such a large number of removals.

There are two reasons for an assembly being deleted from the List. Either the assembly was deleted by the Foundation for cause

(e.g., components of the assembly were changed without being approved) or it was deleted because of some action taken by the manufacturer. In most cases, the latter means the manufacturer either requested the assembly to be removed from the list, or the manufacturer stopped producing spare parts for the assembly. Section 10.2.1.5 of the Ninth Edition of the Manual states:

...When the original manufacturer ceases to maintain a supply of original design replacement parts for an approved model and size of assembly that particular model and size shall have its Approval rescinded.

So, when spare parts are no longer available from the original manufacturer, the assembly is removed from the List. When the design of

an assembly has been changed without notifying the Foundation, the Foundation works with the manufacturer to correct the situation then, that information is immediately communicated to Foundation members via a Special Notice. Should the manufacturer not be able or willing to correct the problem, the assembly would be removed from the list of approved assemblies.

Generally, assembly deletions are a result of the manufacturer deciding that it will no longer produce original spare parts for an

approved assembly. The Foundation does not require that manufacturers maintain spare parts for their products for any period of time. And, any assembly that has been modified, this includes using spare parts from a source other than the

original manufacturer, invalidates any Foundation approval.

Once an assembly is removed from the List, for reasons addressed above, that assembly is no longer approved by the Foundation. If the assembly is deleted for spare part issues, it is up to local jurisdictions to determine whether it will allow assemblies that are no longer manufactured or lack original spare parts to continue in operation.

For example, a local jurisdiction may allow an assembly that was once approved, but has

USC UNIVERSITY OF SOUTHERN CALIFORNIA
 Foundation for Cross-Connection Control and Hydraulic Research

List of Approved Backflow Prevention Assemblies
 17 November 2008
 Supersedes All Prior Lists

Notice
 The original Certificate of Approval - identified by the Edition of the Manual and the Approved date shown below - is valid only if the original or renewal date shown hereon is within three (3) years of the current date. The responsibility to request a renewal of an Approval is that of each manufacturer. The Foundation retains the right of determining the extent of re-evaluation required before renewal is granted. Certificates of Approval are not recalled for the purpose of updating the effective date. This revision of date is only published via the current List of Approved Backflow Prevention Assemblies.

Unless otherwise specified by the manufacturer all assemblies are to be installed on cold potable water applications - below 110°F. Also all of the assemblies listed are approved for **INDICATED ORIENTATION ONLY** (Please see the legend to the right). Use of spare parts other than those of the original manufacturer invalidates the Approval.

Most Recent Updates

Manufacturer/Model	Size	Orientation(s)	Approved
Double Check Valve Assemblies			
Ames Colt 200	10	H	2-May-2008
Ames Colt 200	11	H	2-May-2008
Ames Maxi-Stop	8	VU	2-May-2008
Ames Maxi-Stop	10	H	2-May-2008
Watts 757	10	VU	2-May-2008
Watts 767	8	H	2-May-2008
Watts 767	8	VU	2-May-2008
Cash Acme DCV	3/4	H	20-Oct-2008
Cash Acme DCV	1	H	20-Oct-2008
Cash Acme DCV	1 1/2	H	20-Oct-2008
Ames Maxi-Stop	6	VU	20-Oct-2008
Ames Maxi-Stop	8	H	20-Oct-2008
Ames Maxi-Stop	10	VU	20-Oct-2008
Ames Maxi-Stop	12	H	20-Oct-2008
Ames Maxi-Stop	12	VU	20-Oct-2008
Reduced Pressure Principle Detector Assemblies			
Wilkins 375ADA	3	H	20-Oct-2008
Wilkins 375ADA	2 1/2	H	20-Oct-2008
Spill Resistant Vacuum Breakers			
Wilkins 460	1/4	VUH	8-May-2008
Wilkins	1	VUH	8-May-2008

Orientation of Assemblies

DC, DCDA, RP, RPDA
 AVB
 Sample

USC Viterbi School of Engineering

2008 © University of Southern California Page 1 of 32

continued on page 7

Winterizing Backflow Preventers: continued

continued from **page 1**

With this trapped volume of water freezing, the resulting damage can be significant. Seals or components may be distorted and in extreme cases the body housing itself could be cracked. With the valve in the fully opened or closed position, a small pocket of water may be trapped. It is highly recommended that the ball valve be left in a partially opened position. Leaving the valve at a 45-degree angle will leave this pocket unsealed and the trapping of water will be significantly reduced, thus avoiding any damage to the valve.

Below you can see where the trapped water would collect if a valve is left open.

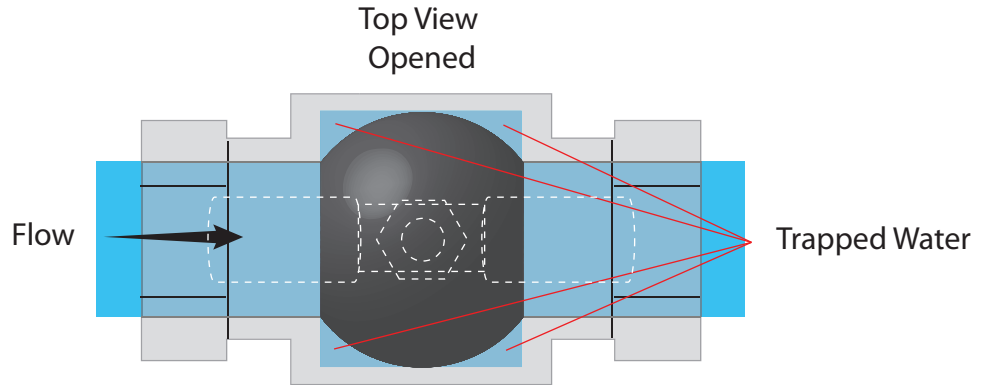

Below you can see where the trapped water would collect if a valve is left closed.

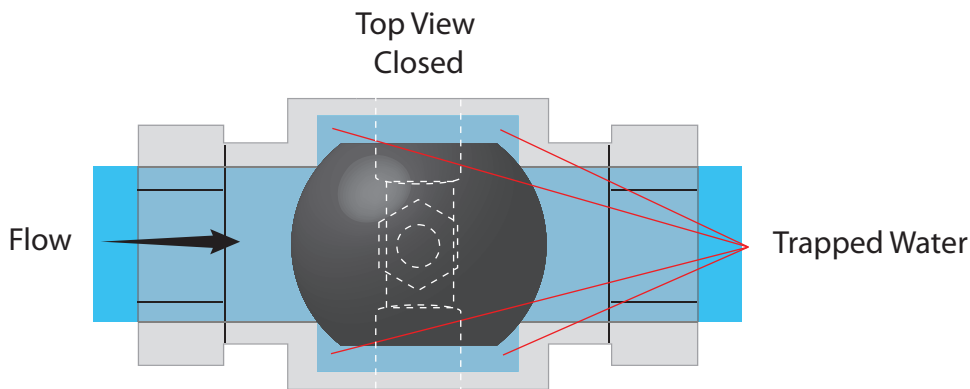

Ideally backflow preventers used in environments with freezing temperatures should be kept in an area (i.e., building, basement) protected from the harsh environment. However, this is not always possible or practical. For those backflow prevention assemblies that are on water lines that must operate during winter months; enclosures can be used

to protect the assemblies from freezing. Enclosures may generally be separated into two categories; freeze retardant enclosures (i.e., non-heated) and freeze protection enclosures (i.e., heated). In addition to weather protection backflow enclosures may be used to protect from vandalism.

It is important to note that any enclosure used on a reduced pressure principle backflow assembly or vacuum breaker must have enough room for water discharge from the relief valve or air inlet area. ■

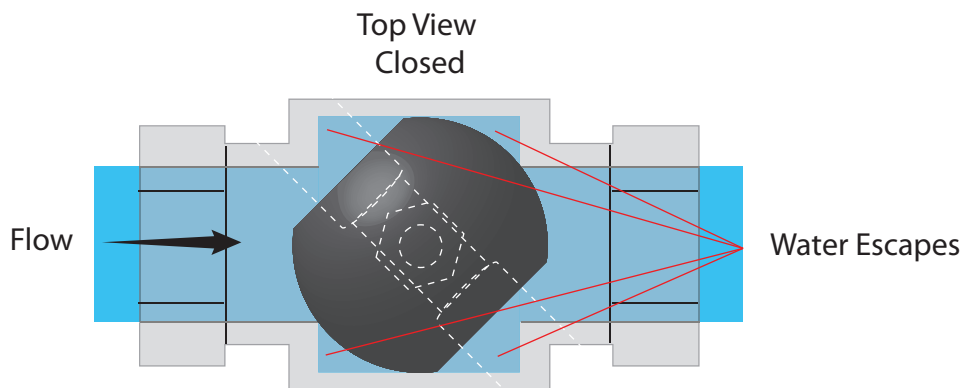

A valve left at a 45-degree angle will allow water to escape from the concerned pockets as a result reducing risk of damage.

Field Testing the RP- Leaky #2 SOV

While field-testing the reduced pressure principle assembly, it is common to come across an assembly that has a leaking No. 2 shutoff valve. The Ninth Edition of the Manual has instructions on how to handle this in Section 9.2.3.3. However, there are some portions of this test that are unclear. In Section 9.2.2, test No. 1 step j, it states:

If the low side control needle valve must be opened more than one-quarter (1/4) turn to lower the differential pressure reading to the relief valve opening point, then see Troubleshooting Section 9.2.3.3.

In the troubleshooting section the tester is informed that a temporary bypass hose should be attached to the assembly across the Nos. 1 and 4 test cocks. However, **the Manual fails to mention that the low side control needle valve should be closed before attaching the temporary bypass hose.** Section 9.2.3.3 states that once the bypass hose is attached and the reading has stabilized the tester should return to Section 9.2.2, test No. 1, step j.

Step j tells the tester to open the high side control needle valve approximately one turn, and the low side control needle valve no more than one-quarter turn. The problem is that the instructions never told the tester to close either of these needle valves, so the tester may have left them open.

The Tenth Edition of the Manual will specifically instruct the tester to close the low side control needle valve before attaching the temporary bypass hose from the No. 1 test cock to the No. 4 test cock. It will also instruct the tester on how to continue the test with the temporary bypass hose attached.

Excerpts from the Tenth Edition follow, but the excerpts here do not account for backpressure or leaks that are too great to correct with this method. Those scenarios are, however, included in the Tenth Edition.

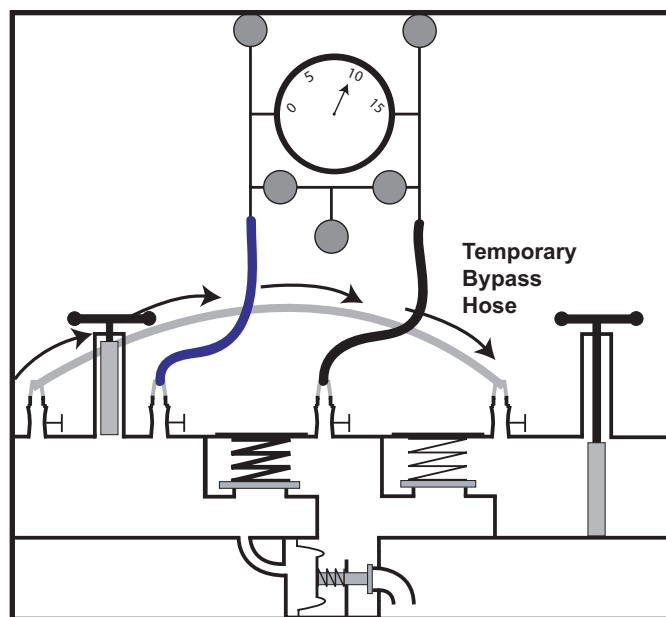

Fig. 9.2- Compensation for No. 2 Shutoff Valve Leak

Section 9.2.1.2 (5 needle valve field test kit), test No. 1, step j (Tenth Edition)

j. Open the high side control needle valve approximately one turn, and then slowly open the low side control needle valve no more than one-quarter (1/4) turn to bypass water from the No. 2 test cock to the No. 3 test cock. Observe the differential pressure reading as it slowly drops to the relief valve opening point. Record this opening point value when the first discharge of water is detected.

- If the low side control needle valve is opened one-quarter (1/4) turn and the reading does not decrease to the relief valve opening point, then see Diagnostics Section 9.2.1.3.4 - Instructions for Leaking No. 2 Shutoff Valve.

9.2.1.3.4 Instructions for Leaking No. 2 Shutoff Valve (See Fig. 9.2)

If the differential pressure reading on the Field Test Kit during Test No. 1, step j, does not decrease to the RV opening point, and the low side control needle valve is opened one quarter (1/4) turn, it is likely that the No. 2 shutoff valve is leaking. Close high side and low side control needle valves. The No. 2 shutoff valve should be re-opened and closed in an effort to get a

continued on page 7

ABPA certification at Specialist Courses

This year the American Backflow Prevention Association established a Specialist Certification program. As a result, the Foundation began to make available to all students at its Course for the Training of Cross-Connection Control Program Specialists the opportunity to obtain ABPA specialist certification.

The Program Specialist course covers the intricacies of administrating a cross-connection control program; for example, determining where backflow preventers are necessary to protect the potable water system.



Any student who attends the Program Specialist course has the option, at the end of the course, to take the ABPA Specialist Certification exam. Prior to the ABPA exam certification becoming available, students had an option of either taking the USC exam or the California/Nevada Section of the American Water Works Association Specialist exam. Now all three exams will be made available to all students, but keep in mind students may only choose ONE exam to take at the end of the course week.

In order to qualify for ABPA Specialist Certification the applicant must hold a current ABPA Backflow Prevention Assembly Tester Certification or expired ABPA Backflow Prevention Assembly Tester Certification. If the applicant is not a current or expired ABPA certified tester he may show proof of either having a current or expired tester certification from a recognized certification program.

ABPA Specialist Certification is valid for a period of three years after which the specialist must recertify by taking a recertification examination.

The application fee is \$75 (payable to the ABPA), which is NOT part of the initial course payment. Students at the beginning of the course will be notified of the exam options and will be asked to fill out the appropriate form if they wish to apply for either the ABPA or the CA/NV AWWA certification. Payment for those certification programs is to be turned in with the application on the first day of class. If taking the USC exam; no further steps need to be taken. Students taking either the ABPA exam or the CA/NV exam will also be credited with successfully completing the USC training course, assuming a passing score is achieved.

For the most part, cross-connection control specialist certification programs are not specified in many state rules or regulations. Local jurisdictions may also have different qualifications for program specialists. Check with your local water or health agency to determine what steps you may need to follow to be recognized as a cross-connection control program specialist.

For more information about the ABPA certification please call 877-227-2127 or visit the ABPA website at www.abpa.org. Information on CA/NV AWWA certification may be found at www.ca-nv-awwa.org. For questions concerning the Specialist course please call the Foundation office. ■

Reminder: New Member Rates Next Month

In December the Foundation will be mailing renewals to all its January members that will reflect the new member rates referred to in the Summer 2008 Cross Talk.

Company member rates will increase twenty dollars to \$120. New membership rates for water purveyors are the following: less than 2,400 service connection (\$120); more than 20,000 service connections (\$1,000); and more than 2,400 service connection, but less than 20,000 (\$0.05 per connection). State, federal and county agencies membership rate will remain the same (\$500.00). ■

List Deletions: continued

continued from **page 3**

been deleted for original spare parts issues, to continue in operation until it needs repairs that require spare parts. Other agencies may simply require that any assembly that has lost its approval be removed from the jurisdiction. The policies may vary depending on the type of assembly (i.e., double check valve assembly, or reduced pressure principle assembly) or the application (i.e., health hazard). Contact the local jurisdiction for more information.

Ultimately, if the Foundation is notified by the manufacturer that an assembly will no longer have any original spare parts available it will be deleted from the List. If you have questions regarding deletions from the List feel free to contact the Foundation via phone or e-mail. ■

Field Testing the RP: continued

continued from **page 5**

better seal. This may particularly occur when testing units, which do not have resilient seated shutoff valves. Make sure that hose fittings are drip-tight. Return to Test No. 1, step j. If this does not correct the leak in the No. 2 shutoff valve, then continue below...

Close low side control needle valve (high side control needle valve remains open). Attach temporary bypass hose to No. 1 test cock and bleed all air from the temporary bypass hose by opening No. 1 test cock, then close. Attach the other end of the temporary bypass hose to No. 4 test cock. Fully open the No. 1 test cock to pressurize the temporary bypass hose. Slowly open No. 4 test cock to the fully open position, observing the reading on the Field Test Kit.

- If the differential pressure reading stabilizes above the relief valve opening point, re-open the low side control needle valve no more than one-quarter turn...
- If the differential pressure reading decreases, observe the differential pressure reading as it slowly drops to the relief valve opening point. Record the opening point value when the first discharge of water is detected. If the differential pressure reading drops to zero, and the differential pressure relief valve does not discharge any water, record that the differential pressure relief valve did not open. Close the low side control needle valve. Open the low side bleed needle valve, once the reading reaches a value above the apparent No. 1 check valve reading, close the low side bleed needle valve. The No. 2 check valve is recorded as "closed tight," and the reading indicated is the actual static differential pressure across the No. 1 check valve and recorded as such. The No. 2 shutoff valve should be recorded as leaking. Return to Test No. 3 step b.

The basic field test and principle for field testing the RP remain the same, however, the clarification in the Tenth Edition should eliminate some of the questions Testers have. ■

Training Courses

Tester Course

Los Angeles, CA
26-30 January 2009

Los Angeles, CA
1-5 June 2009

Specialist Course

Los Angeles, CA
5-9 January 2009

Baton Rouge, LA
2-6 March 2009

Upcoming Events

ABPA- Oregon Annual Conference
Wilsonville, OR
15 January 2009

TREEO Cross-Connection
Control Conference
Crystal River, FL
25-27 February 2009

AWWA CA/NV
Spring Conference
Santa Clarita, CA
6-9 April 2009

Contact Information

Phone: 866-545-6340

Fax: 213-740-8399

E-mail: fccchr@usc.edu

Website: www.usc.edu/fccchr

Foundation for Cross-Connection Control and Hydraulic Research

University of Southern California
Kaprielian Hall 200
Los Angeles, California 90089-2531

First Class
US Postage PAID
University of
Southern California